



Hot Cathodes, Cold Cathodes

Prepared by Nanox

Introduction

X-rays were discovered over 125 years ago. The father of X-rays was Wilhelm Conrad Röntgen, a German physicist who presented his paper 'Über eine neue Art von Strahlen' ('On a New Kind of Rays') to the Würzburg Physical Medical Society in December 1895. These rays had been labeled with the letter 'X' to represent their unknown nature, which is understandable as at that time, there was no knowledge of the nature and characteristics of radiation. The knowledge we have gained about X-rays belies the name today, as we now possess extensive information about all aspects of X-rays.

Modern X-ray and the evolution of radiologic modalities started in 1913 by introducing tungsten filament to the cathode part of the "Coolidge" tube, which supplied far better reliability than the preceding technologies. Over a hundred years later, X-rays continue to be generated by electrons supplied by heating tungsten filaments. The history of radiology is the history of the "Hot Cathode" invented by Mr. Coolidge.

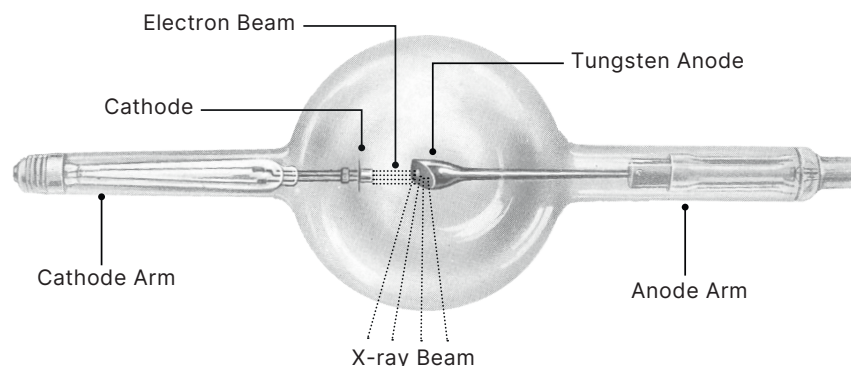

Figure 1 - The "Coolidge" tube invented by William D. Coolidge (1873~1975)





The Basic X-ray Tube

The X-ray tube operates by accelerating an electron beam from a relatively negative-charged source, called a cathode, to a relatively positive-charged target, called an Anode. Upon hitting the Anode, the electrons release their energy in the form of heat (around 99% of the energy) and X-rays (mainly as bremsstrahlung and characteristic radiation).

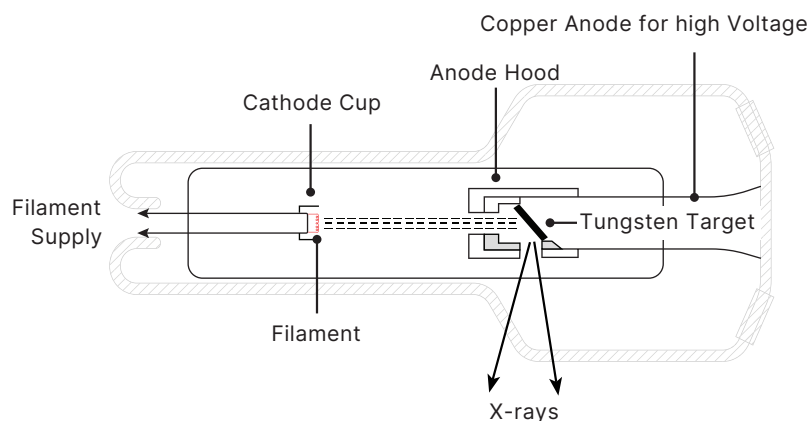

Figure 2 -Basic X-Ray tube

The Cathode is a crucial part that provides the electrons used to generate the X-rays. The process by which a conventional Cathode emits electrons when it is heated is called thermionic emission. The process is very much similar to that of an Edison light bulb. In X-ray tubes using these thermionic Cathodes, the Cathode utilizes a filament which is electrically heated to incandescence, so it emits free electrons (instead of visible light in the light bulb).

The number of free electrons emitted by the Cathode depends on two factors: the level of heat applied, and a property of metals called the work function. The higher level of heat is applied, the more electrons are emitted. Similarly, if a lower temperature is applied, fewer free electrons are emitted. The minimum amount of energy required to remove the free electrons from the metal is called the work function. Metals with low work function require less heat energy to emit free electrons, whereas those with a high work function require more heat energy. Most thermionic emitters used in X-ray production include oxide-coated Cathode, Tungsten, and thoriated Tungsten.



Cold Cathodes

In the early 21st century, several big X-ray players tried implementing non-thermionic electron emission technology, called “Cold Cathode” technology - but none achieved significant success. Consequently, medical X-ray tubes still use thermionic emission technology when all other thermionic tubes are obsolete in other technology fields.

Nanox has a Cold Cathode technology that has solely proved its viability in the electronics industry¹, successfully upgraded the performance to medical applications, and is developing radiological systems that break the limitations impeded by the traditional Hot Cathodes.

What is a Cold Cathode?

Principle

The term “Cold Cathode” refers to a cathode that is not electrically heated by a filament. While a filament boils off electrons by using heat (called a thermionic emission) - a Cold Cathode (or a “field emitter”) extracts electrons from the metal by an external electric field.

Cold Cathode (or “Field Emission”) technologies attracted first professional interest in the late 1990s to early 2000s when flat LCD panels were considered for big-screen solutions. To make a thin flat CRTs, almost all electronics makers of the world joined the race to develop Field Emission Displays (FEDs). In the display panel, millions of small pixels must be driven independently. Therefore, all research projects adopted micro-gate construction.

¹“Technically a Sony’s spinout, Field Emission Technology Inc. made great success showing very high quality, 24-inch FED in the first decade of the 21st century. However, they were unable to obtain funding to establish a production line, due to international economic slowdown at the end of the decade, and that was the end of FED.” - A brief history Vacuum Nanoelectronics by Capp Spindt, SRI International.

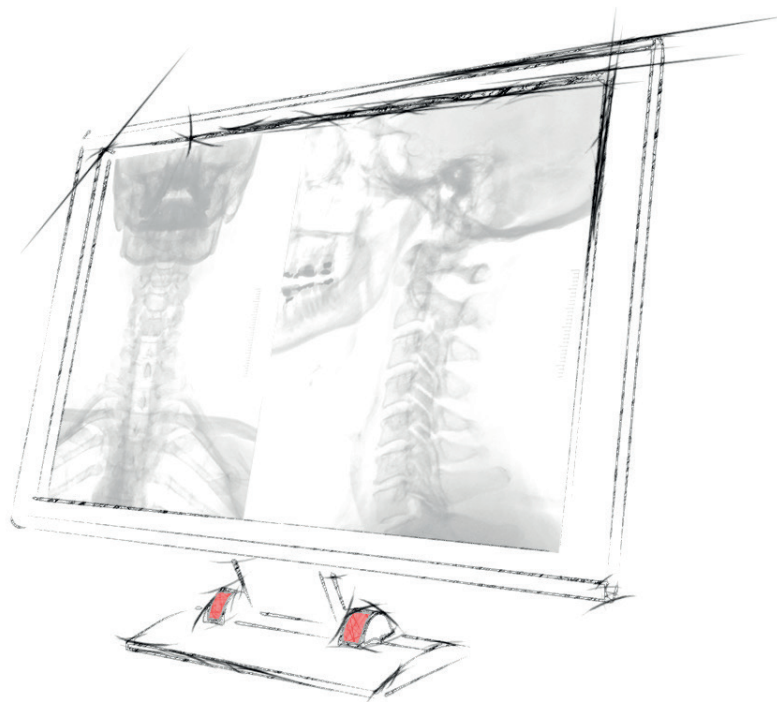

Figure 3 - The field emission display (FED) of Nanox's pre decessor (2018) renowned for its award-winning quality



Figure 4 - Sony presents its first working prototype of its FED-based TV in 2008



Benefits of Cold Cathode X-ray tubes

In the medical imaging sector, the use of a Field-Emission-type X-ray tube has many desirable properties:

1. Size improvements:

Field emission type tubes can be made much smaller and lighter than regular X-ray tubes. This can drastically reduce the size and complexity of imaging systems, and consequently – their cost.

2. Energetic efficiency

Electrons are extracted from the metal cathode by applying an electric field, while the temperature of the emitters stays at room temperature, significantly lower than that of the hot Cathode filaments. As no filament heating is required to “boil off” electrons of the Cathode, cold cathode X-ray systems are more energy-efficient than Hot Cathodes. This feature is most beneficial in mobile imaging units that run off chargeable batteries.

3. Colder Mechanisms

Electrons are extracted from the metal cathode by an applied electric field, while the emitter temperature is significantly lower than that of Hot Cathode (thermionic emission) filaments. Hot Cathode temperature is over 2000 degrees Celsius while a Cold Cathode temperature is that of room temperature.

4. Rapid time switching

In a Hot Cathode, the acceleration of the electrons towards the Anode (thereby creating X-rays) is done by activating and switching a high voltage supply. This process takes time (on the order of milliseconds). In a Cold Cathode, one can set the high voltage and switch only the gate voltages - a process that can take only microseconds. This feature is most beneficial when short bursts or pulses of radiation are required, like fluoroscopy.

5. Current-Voltage decoupling

The Field Emitter current depends on the applied voltage, and the X-ray intensity depends on the Field-emitter’s current. With cold cathode technology, it is possible to uncouple these two parameters, i.e., the current’s power is independent of the voltage. Thus, the X-ray intensity can be rapidly controlled by increasing the speed of switching or by creating short pulses.

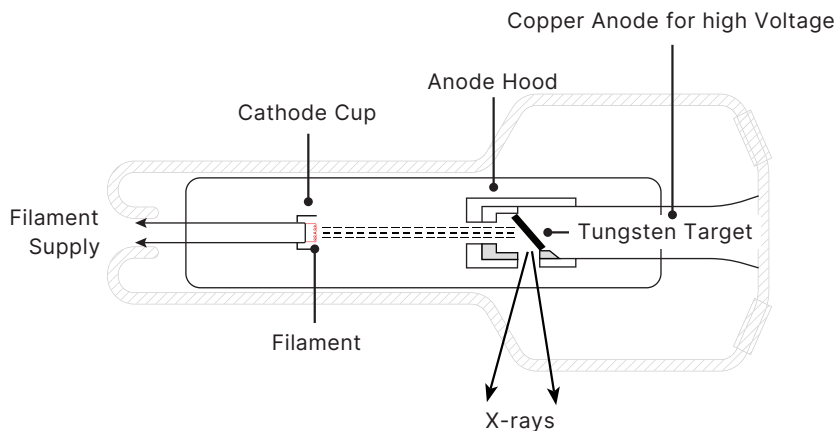

Hot cathode X-ray source (filament)
Extracts an electron cloud by heat

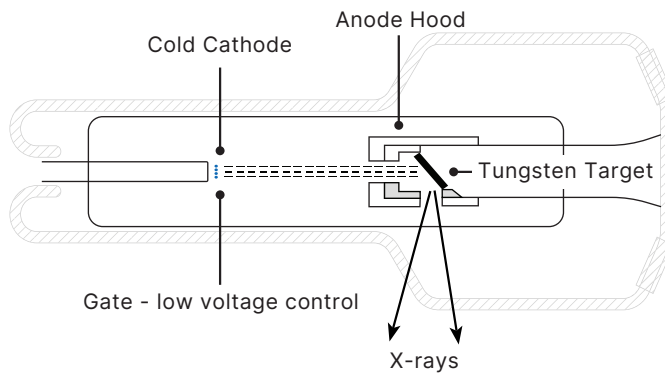

cold cathode X-ray source (field emission)
Extracts electrons by applying an electric field



Types of Cold Cathodes

There were several attempts to create robust and stable Cold Cathode sources throughout the development history of X-ray-based medical imaging devices.

The two most deeply studied designs are the Spindt cones, based on metal field emission tips, and Carbon Nanotube (CNT) emitters.

Both technologies have their limitations: either in ion bombardment of cathode tips, that resulted in erosion (i.e., sputtering) of the tip and eventual destruction of the Cathode, or in greater sensitivity to cathode damage induced by gate-to-base electrical shorts.

These limitations posed a significant impediment to the Cathode's current density, which in turn constrains the intensity of the X-ray radiation. Despite extensive research, up until now, Cold Cathode technology has not been extensively employed in medical imaging devices. The differences between Nanox Technology and the current Cold Cathodes are broadly discussed in the following paragraphs.

CNT technology

Carbon Nanotubes (CNTs) are a type of carbon spatial formation with a cylindrical crystal structure, first discovered in 1991. CNTs are long, hollow shaped tube structures with a high aspect ratio. Their walls are formed by graphene. CNTs can be synthesized using multiple techniques, such as arc discharge, laser ablation, or chemical vapor deposition. Due to the sharp tip of CNTs, an enhanced electrostatic field is created, making it easier for electrons to tunnel through the material wall and exit the tip. CNTs have been studied as field emitters from as early as 1995.

The basic CNT X-ray tube design is comprised of a CNT cathode, a grid (or mesh) electrode, and an anode, as depicted in Figure 5. The gate mesh is placed above the tips of the CNTs and applies the required positive voltage gradient to draw out the electrons from the tips of the nanotubes. The electrodes are then accelerated through the mesh to hit the Anode and create the desired X-rays upon impact.



The CNT cathode current depends on many factors such as the density of CNTs, the area of deposited CNTs, the voltage between the gate electrode and Cathode, and the gate mesh design².

Because of their mechanical, electrical properties and low cost, CNTs were thought to be an ideal Cold Cathode. However, no technique to grow CNT in a selected place has yet been established. CNTs supplied off-line are “printed” or “pasted” on a substrate. The CNT binder deteriorates over time, spreading in the tube vacuum and shortens the product lifetime.

Moreover, these randomly positioned CNT edges actually make the electric field weak, as a whole

- The tubes edges that are placed under a relatively strong electric field, were burning out fast
- CNT edges break off by repeated static electric forces
- The changing and deteriorating electron beams must be controlled all the times
- The exterior grid structure wastes more electrons and requests high voltage³.

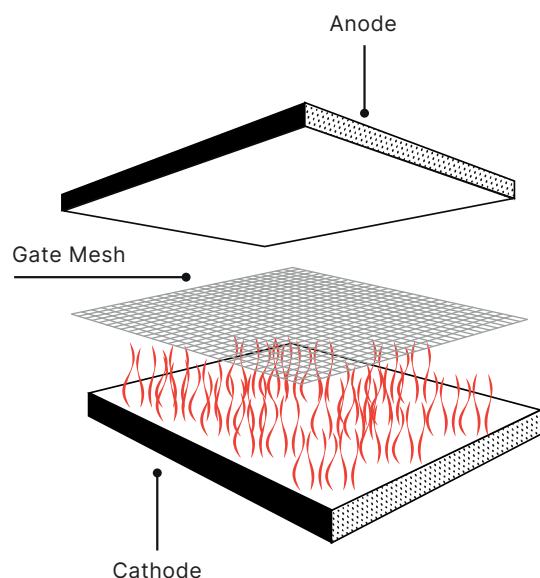

Figure 5 - CNT tube basic design

²Jing Shan: Development of A Stationary Chest Tomosynthesis System Using Carbon Nanotube X-Ray Source Array (Dissertation Under the Direction of Otto Zhou), Chapel Hill, 2015

³A CNT cold cathode requires over 1,000V to extract electrons, while a Spindt cold cathode requires 100V, and the Nanox source <50V.



These problems continued even when manufacturers tried integrating CNT in medical applications.

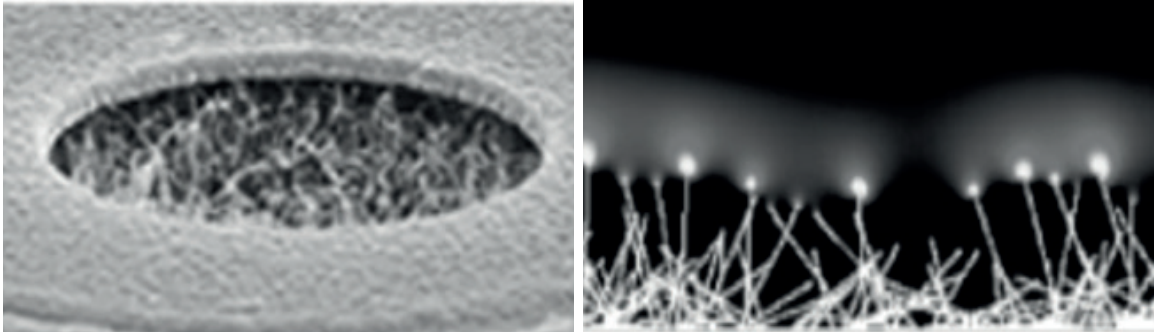

Figure 6 - Carbon Nanotubes (CNTs) emitters

Spindt cones

Another traditional Cold Cathode solution is called the Spindt cone. The Spindt cone is named after Capp Spindt, a senior fellow of SRI International, who invented the structure in the late 1960s. Unlike CNTs, an edge of a Spindt cone is positioned just below the center of a gate hole. The gate structure is smaller than the CNTs grid structure and requires lower voltages to extract electrons: a CNT cold cathode requires 1,000V to extract electrons, whereas a Spindt cold cathode requires only 100V.

However, as it goes to high currents, some gate-cone structures “explode” by micro discharges. This phenomenon results in unpredictable performance and a short lifetime.

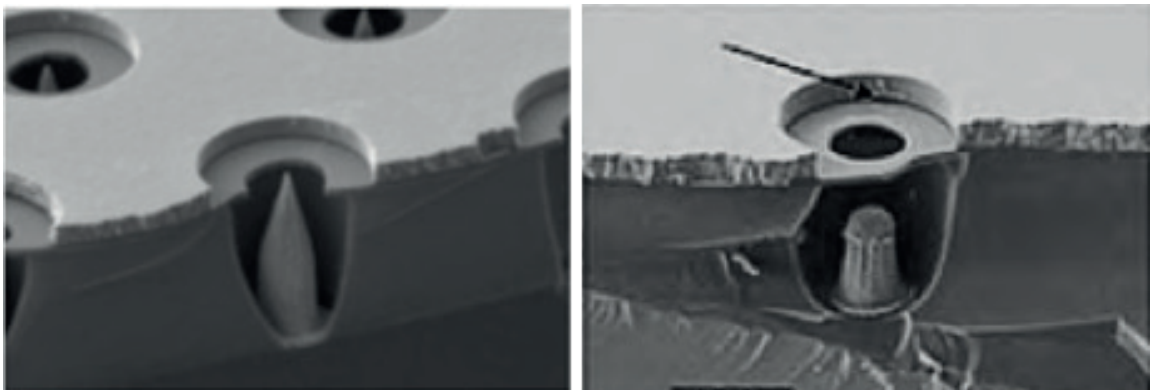

Figure 7 - A high-power Spindt cone of SRI International and its destruction



Nanox technology

Until now, basic Cold Cathode designs failed to achieve the quality level, efficiency, and lifetime required for commercial products.

Nanox has answered the problems that plague other Cold Cathode technologies by accumulating a much higher number of emitter/gate structures of far smaller sizes. In its current standard design, hundreds of millions of nanometer-sized gates and conical tips are fabricated on a silicon chip, one square centimeter in size. Nanox emitters are far more uniform than Carbon Nanotubes and orders of magnitude smaller than conventional Spindt-type cathodes.

This design provides the following realistic solutions:

1. The position of the edge of each emitter cone is specified and fixed⁴.
2. A very high electric field is induced at the nanoscale gap between the emitter cone and the gate hole. This high electric field is possible even by applying a voltage as low as 50 volts at the gate. The high electric field is highly effective at extracting electrons from the emitter.
3. The load shared by every single emitter is minimal (a few nano-amperes per each emitter results in the emission of a few amperes per square centimeter⁵), which hardly damages the nanostructure.
4. The emission performance can be freely designed by combining the size of the nanostructure and its density⁶.

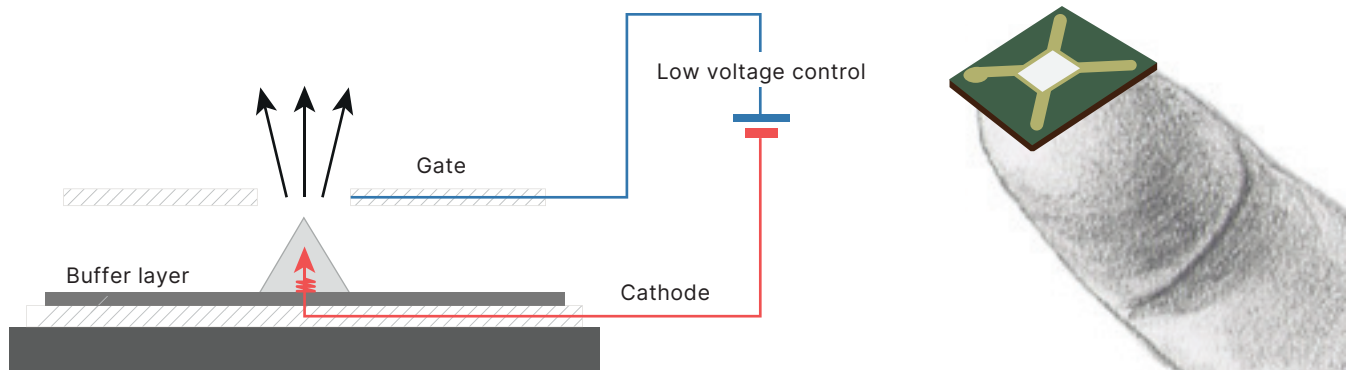

Figure 8 - Nano-Spindt Cold Cathode Chip Technology



⁴The size of the nanostructure is closer to that of a CNT device, while other problems are avoided.

⁵A single standard Spindt emitter is loaded more than 100 times to Nanox's nano-Spindt. In the nano Spindt design, micro discharges rarely happen, or if they do, seldom break the whole structure.

⁶To get a higher emission as a whole, it is better to make larger number of smaller emitters. Nanox designed a gate hole as little as 100 nanometers and increased the emitter density.



Comparison of the Nanox source to CNT emitter

C ompared to CNT, the Nanox field emitters are far more uniform in nature than that of CNT emitters.

The size of the nanostructure is close to that of a CNT device, making the electrons emission possible, while the emitters are protected by the gate structures and are far less susceptible to damage that may occur, if free Tungsten from the Anode becomes deposited on the emitter.

Nanox FED	CNT
Sturdy gate structure makes up the majority of the emitter surface	No gate structure to protect tips
High Tip uniformity < 50V	Low tip uniformity > 1000V
	
High efficiency	Grid limits efficiency due to absorption
Only tip of cone is susceptible to ion beam damage.	The entire CNT is susceptible to ion beam damage
Tungsten metal deposition has minimal impact on the work function of the Nano Spindt tip material.	High susceptibility to ion bombardment. Tungsten metal deposition increases the work function of carbon on all surfaces.

Table 1 - Comparison of Nanox technology and current Carbon Nano Tubes (CNT) Technology



	Nano-Spindt cone emission	CNT
Efficiency	High efficiency due to sturdy gate design, millions of nano-gates manufactured on a nanoscale chip	Limited efficiency due to grid structure and absorption on the grid, as well as tungsten metal deposition increasing the work function of the carbon tips.
Longevity	Limited metal edge exposure provides for high efficiency and longevity	Inability to maintain efficiency for prolonged periods.
Uniformity & Stability	High tip uniformity and low burn off due to low cone tip exposure, and no risk of tungsten metal deposition on work function	High burn-off of tungsten metal edge and low tip uniformity - reducing stability
Better image quality	Faster switching and better synchronization with digital image receptors, reduce image blurring and patient movement artifacts	
Power management	Supply of less than 50V is required to activate electron ejections from the chip and enable voltage-independent current (X-ray dose)	Supply of over 1000V is necessary to activate electron ejections

Table 2 – Nanox nano-Spindt cone vs. CNT technology

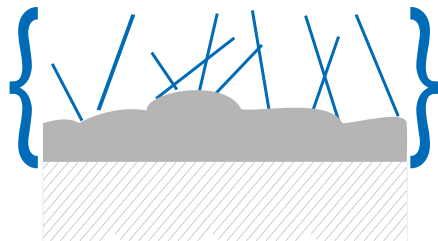

High-Voltage Independence

One of the Nanox chip design's main characteristics is the tiny gap between the nano-Spindt emitters and the gate-holes above them. This small distance results in an extreme voltage gradient at the emitters: The electric field's intensity induced by the gate-hole is on the scale of hundreds of kV per mm.

This design results in Anode HV-independence: Nanox's Cold Cathode can generate any desired current, irrespective of the Anode voltage, only by applying a relatively minute and pre-determined voltage at the gate-hole. This current is stable and uninfluenced by the Anode high voltage. Figure 9 shows that above 10kV, the Cathode-to-Anode voltage does not influence the tube current (noted as I_a , in blue). Typical kV in radiography range from 40-120kV and 22-49kV in mammography.

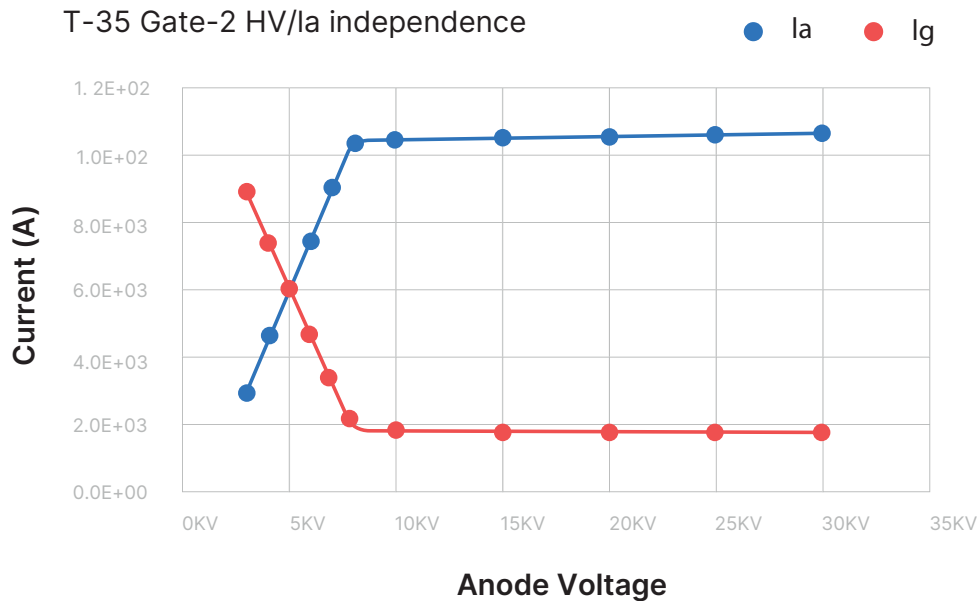

Figure 9 - Hight Voltage independence



High speed pulsed electron beam generation

In a Hot Cathode X-ray tube, turning on and off the electrons beam towards the Anode is done by switching a high voltage supply. This process takes time (on the order of milliseconds).

The Nanox cold Cathode chip is driven by pulses and does not need constant filament current, like in hot Cathodes. One can set the high-kV Anode-to-Cathode voltage at a specific, constant level – and switch only the chip gate voltage – a process that can take microseconds. This is an improvement in the range of three orders of magnitude. In this operation mode, the X-ray pulses are perfectly square with no leading or trailing radiation edges, contributing to efficiency and dose savings.

Focal Spot Flexibility

Nanox's chip and tube design can change the size, position, and shape of the tube focal spot. This can be done digitally and dynamically during both radiological and fluoroscopic studies. The focal size and shape can be adjusted on the fly by either operating certain gate groups on the Nanox chip, or dynamically using the tube focus ring – a component placed between the Cathode and the Anode and used to focus the electrons on a smaller spot of the Anode – thereby improving the image detail.

Changing the focal size can be highly beneficial in managing the Anode heat for X-ray tubes using a stationary (non-rotating) Anode– focal size can be dynamically increased or decreased for each type of study or the current heat load of the Anode – thereby extending its operational lifetime. Digitally adjustable focus size can also be used in certain study scenarios, such as quickly switching to view thin metal wires during angiography or imaging small body structures. Figure 10 shows the process of changing the focal size in a Nanox tube.

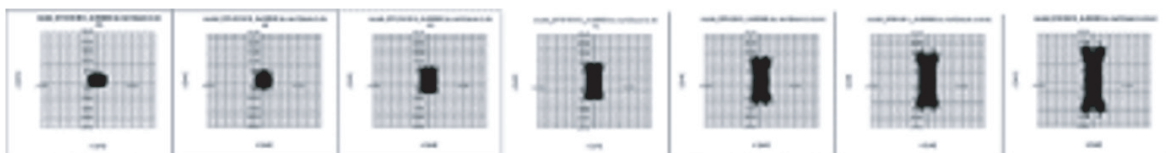

Figure 10 - Digitally flexible focal spot



From Cathode to X-ray tube

In its design, Nanox has created disruptive and ground-breaking innovation in the X-ray imaging market for the first time in over 100 years. Nanox proprietary cold cathode technology is the first to achieve the high-grade performance, power efficiency, reliability, and longevity required for today's imaging, which is also flexible, compact, and cost-efficient.

Nanox routinely tests, verifies, and perfects its Cold Cathode technology in various medical scenarios by setting the Cathode to X-ray tubes initially available for Hot Cathodes. The design is being continuously improved and verified.

The Nanox Cold Cathodes are tested in sealed and independently working tubes. This testing scheme is unique and highly appreciated, as other Cold Cathode technologies are usually tested in special vacuum chambers and rarely in a realistic medical environment. Nanox commercializes the new X-ray source based on the expertise of these tube design and making.

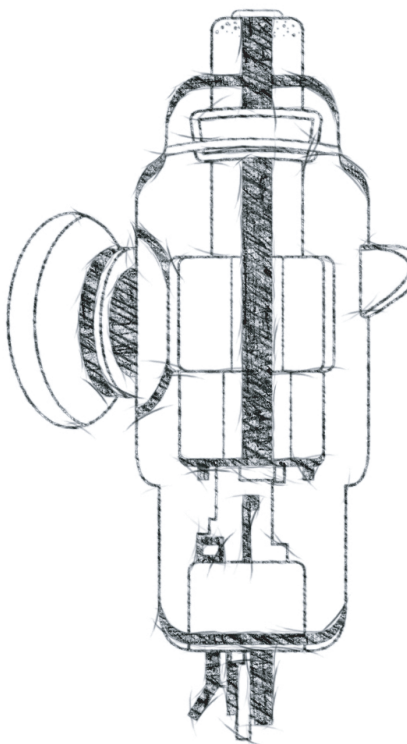

Old 50mm tube

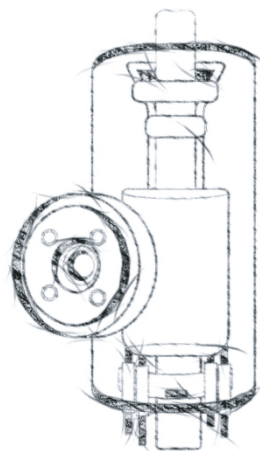

Present 35mm tube

**The tube is simple and compact,
and is digitally controlled.**



From X-ray tube to Modality

Nanox's technology is the solely available Cold Cathode technology viable in the long term, for medical X-ray devices. However, the new technology is not merely a replacement of tungsten filament, but also a presentation of innovative medical solutions possible only with new X-ray sources made with Cold Cathodes. Such solutions shall employ rapid switching and HV-independent (space-charge free) X-rays, with flexible focal spots - all being digitally controlled in simple, compact, and economical packages.

Some of these modalities may include stationary and mobile imaging units, fixed source array for Tomosynthesis and CT, fluoroscopy, and dual-energy applications – all incorporating Nanox X-ray sources. For this end, the Nanox sources fulfill the following requirements:

- Every source generates sufficient mAs.
- Kilovolt (kV) and focal spot size which are tailor-made for each specific purpose.
- Every source is small enough for many sources to be fitted in the allowed space.
- The total cost of sources is less than the current price of a single tube + its moving mechanisms.
- Reliability for a commercial product.

Proving and verifying these requirements one after another, Nanox has begun producing imaging systems based on the novel Nanox digital X-ray source. These systems demonstrate all its benefits, including a smaller footprint and lower cost, without compromising clinical image quality